

August 1991

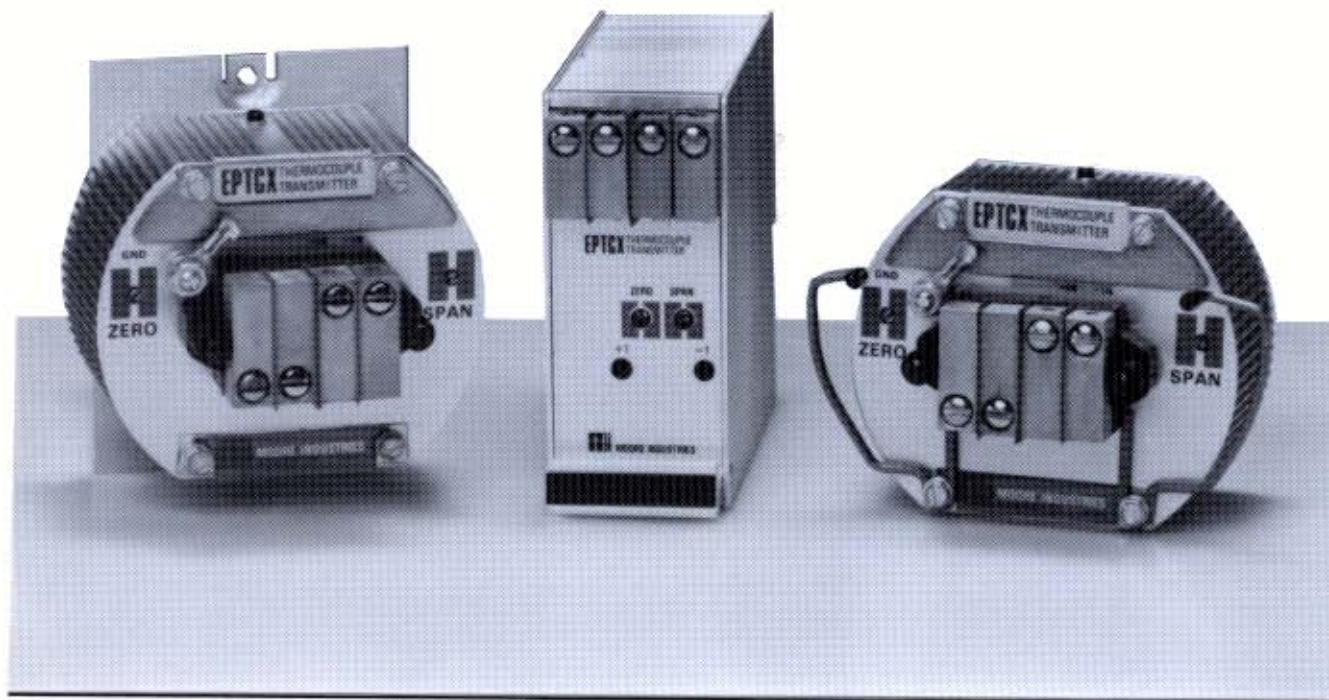

## Table of Contents

|                        |           |
|------------------------|-----------|
| <b>Introduction</b>    | <b>1</b>  |
| <b>Description</b>     | <b>1</b>  |
| <b>Calibration</b>     | <b>3</b>  |
| <b>Installation</b>    | <b>13</b> |
| <b>Maintenance</b>     | <b>15</b> |
| <b>Troubleshooting</b> | <b>16</b> |

**48<sup>HR.</sup>**  
**DELIVERY**



United States/Canada  
**TOLL FREE**  
**1-800-999-2900**

16650 Schoenborn Street  
Sepulveda, California 91343, U.S.A.  
Tel: (818) 894-7111 • Tlx: 65-1322  
FAX: (818) 891-3297  
CONNECT (MacNet): MIISEPULVEDA

United Kingdom  
**FREE PHONE**  
**0800 525107**

1 Lloyds Court, Manor Royal, Crawley  
W. Sussex RH10-2QU, United Kingdom  
Tel: 0293 514488 • Tlx: 87867  
FAX: 0293 536852

Australia  
**TOLL FREE**  
**008 251928**

3/18 Resolution Drive, Caringbah  
New South Wales 2229, Australia  
Tel: (02) 525-9177 • Tlx: 790-75914  
FAX: (02) 525-7296

Ask for the STAR Center

Moore Industries' STAR<sup>®</sup> Center has a wide variety of quality instrumentation in stock and ready to ship.

- Signal Transmitters
- Temperature Transmitters
- P/I and I/P Converters
- Isolators and Converters
- Indicators and Displays
- Alarm Trips
- Integrators and Totalizers
- Power Transducers
- Instrument Power Supplies
- Racks, Rails and Enclosures

Most instruments can be customized to meet your needs. Even then, you'll never have to wait more than a few days.

*Moore Industries*

**STAR**  
CENTER

\* Support, Technical Assistance, and Repair (our Quick-Ship Facility)



# EP-TCX

## Introduction

Moore Industries' Extended Performance Thermocouple Transmitter, the EP-TCX, is a two-wire, loop-powered device that converts standard thermocouple signals to proportional milliamp output.

The unit is most often used to provide a highly reliable interface between standard Instrument Society of America (ISA) thermocouples and recording, monitoring, or controlling instrumentation. The EP-TCX's low output ripple also makes it ideal for use with process computers.

This manual provides descriptions, specifications, calibration information, and installation procedures for Moore Industries' EP-TCX. Notes and Cautions are provided to assist the user in avoiding inconveniences or practices that could result in damage to the unit.

## Description

The EP-TCX is a compact, solid-state unit in an aluminum housing. The housing may be ordered in either of two styles: Moore Industries' Hockey Puck (HP), or space-saving DIN-style (DIN).

When equipped with spring clips, the HP housing can be mounted in a two- or three-hub, explosion-proof enclosure without drilling or tapping. When used with a high-cover, windowed, explosion-proof enclosure, this type of EP-TCX housing is ideal for use with Moore Industries' Display Indicator (DVX), to provide on-site data display.

The snap-in, DIN-style housing allows for a high density of units on a standard, TS-32 "G-rail" (not included).

With Flange Plate (FL or FLD) mounting hardware, HP-style units can be mounted on relay track or almost any flat surface.

Both housings provide access to zero and span adjustment potentiometers on the unit's front panel.

The EP-TCX is set at the factory to accept input from ISA thermocouple types, J, K, E, T, R, and S; or any low-end millivolt source with ranges of 2-5 mV (requires LSC option), 5-10, 10-20, or 20-50 mV.

Its output is also set at the factory for ranges of 4-20 or 10-50 mA. Both input and output are set according to customer specification.

Acceptable input range or thermocouple type, output range, open thermocouple response (upscale or downscale drive), and settings for Elevated Zero (EZ) or Low Input Span (LSC) options may be changed and calibrated in the field. Changes to the EP-TCX operating parameters are effected by repositioning solderless jumpers on the EP-TCX printed circuit boards (PCB's).

There are several design features in the EP-TCX that minimize the problems normally associated with the use of thermocouple transmitting devices.

For example, the unit's solid-state temperature transducer and thermocouple cold-junction are combined in an iso-thermal block on the front panel. This provides automatic cold-junction reference compensation, extending the ambient temperature operating range of the EP-TCX.

Complete isolation between input, output, and the unit housing eliminates the possibility of ground loop currents, preventing false signals production.

Advanced circuitry design provides common mode rejection exceeding 130 dB at 60 Hz. A low-leakage, differential input amplifier eliminates offset error over the operating temperature range, even when thermocouple extension wires are used.

The equipment specifications for the EP-TCX are listed in table 1.

## Options

There are several functional options available with the EP-TCX. For a complete list, or more information, contact your local Sales Representative. Moore Industries may be reached at 1-800-999-2900.

# EP-TCX

**Table 1. EP-TCX Performance and Operational Specifications**

| Characteristics   | Specifications  |
|---|---|
| <b>Input</b>  | Field-selectable for ISA Thermocouple Types J, K, E, R, S, T, or mV source<br><b>Range:</b> Field-selectable<br>1 - 5 mV, full scale (requires Low Input Span Option, LSC)<br>5 - 10 mV, full scale<br>10 - 20 mV, full scale<br>20 - 50 mV, full scale<br><b>Burn-Out Protection:</b> Field-selectable for upscale or downscale drive; default is upscale  |
| <b>Output</b>   | Field-selectable<br>4 - 20 mA (limited to 30 mA, maximum)<br>10 - 50 mA (limited to 65 mA, maximum)<br><b>Ripple:</b> 10 mV peak-to-peak, maximum   |
| <b>Power</b>  | 10 - 42 Vdc, $\pm 50$ mV<br><b>Over-voltage Capability:</b> 70 Vdc, maximum, without damage   |
| <b>Performance</b>  | <b>Load Capability:</b> 4 - 20 mA at 1500 $\Omega$ , maximum; or 1 - 50 mA at 600 $\Omega$ , maximum, when using a 42 Vdc (maximum) power supply<br><b>Calibration Capability:</b> $\pm 0.05\%$ of span, $\pm 0.1\%$ for units with the LSC Option<br><b>Frequency Response:</b> 2 Hz (3 dB point)<br><b>Isolation:</b> Input and output are transformer-isolated with no galvanic path (dc connection between them).<br><b>Common Mode Rejection:</b> Exceeds 35 dB @ 60 Hz<br><b>Line Voltage Effect:</b> $\pm 0.002\%$ of span per Vdc<br><b>Available RF/EMI Protection:</b> 50 V/m -abc = $\pm 0.1\%$ F.S., as defined by SAMA standard 33.1 |
| <b>Controls</b>   | <b>Span:</b> Adjusts output to full scale over entire input range<br><b>Zero:</b> Adjust output to 0% for offsets of -40 to less than 90% (+75 mV maximum) with Positive EZ Option)   |
| <b>Environmental Ratings</b>                                    | <b>Ambient Operating Temperature Range:</b> -29 to +82 °C (-20 to +180 °F)<br><b>Effect on Unit:</b> $\pm 0.01\%$ of span per °C ( $\pm 0.02\%$ of span per °C for units with LSC option)<br><b>Effect on Cold Junction Compensation:</b> $\pm 1\%$ maximum error per 50°C ambient temperature change (for ISA types J, K, R, and S)  |
| <b>Weight</b>   | 141.5 grams (5 ounces)  |
| <b>NOTE:</b> Refer to Installation Section for unit dimensions. |   |

**EZ Option.** Elevated Zero — -40% to -75% of span requires negative EZ, zero greater than +90% of span requires positive EZ (actual anticipated span should be specified by the customer).

**LSC Option.** Low Input Span — Required in applications that call for 2-5 mV full-scale input range.

**RF Option.** Radio Frequency/Electromagnetic Interference Protection — Moore Industries' patented terminal strip with filters and ground plane. Meets SAMA standard 33.1.



# EP-TCX

**Serial number.** A complete, serial-number-dependent history is kept on every EP-TCX that Moore Industries manufactures, sells, or services.

For service assistance, provide the factory with the serial number of the unit that requires attention. The serial number is stamped on a label, and affixed to a side panel of DIN-style units. For HP-style units, the serial number is stamped on a metal tag affixed to the front panel.

**Model Number.** Moore Industries' model numbers identify the type of instrument, functional characteristics, any options ordered, and the housing type. In other words, the model number reflects the way the unit was configured when it originally left the factory. The model number appears on the same label as the serial number.

The example below outlines the significance of each information field in a typical EP-TCX model number.

## Calibration

Every EP-TCX is manufactured according to the customer's specifications. Units are then calibrated and thoroughly tested at the factory prior to shipment to ensure proper performance levels. It is recommended, however, that output values be checked by the user before the equipment is placed into service.

## Controls

All of the housings for the EP-TCX have labeled front panel controls for calibration and adjustment of zero and span. The external span potentiometer works together with the internal coarse control pot to allow the user to set the output to full-scale over the entire selected input range.

### EXAMPLE

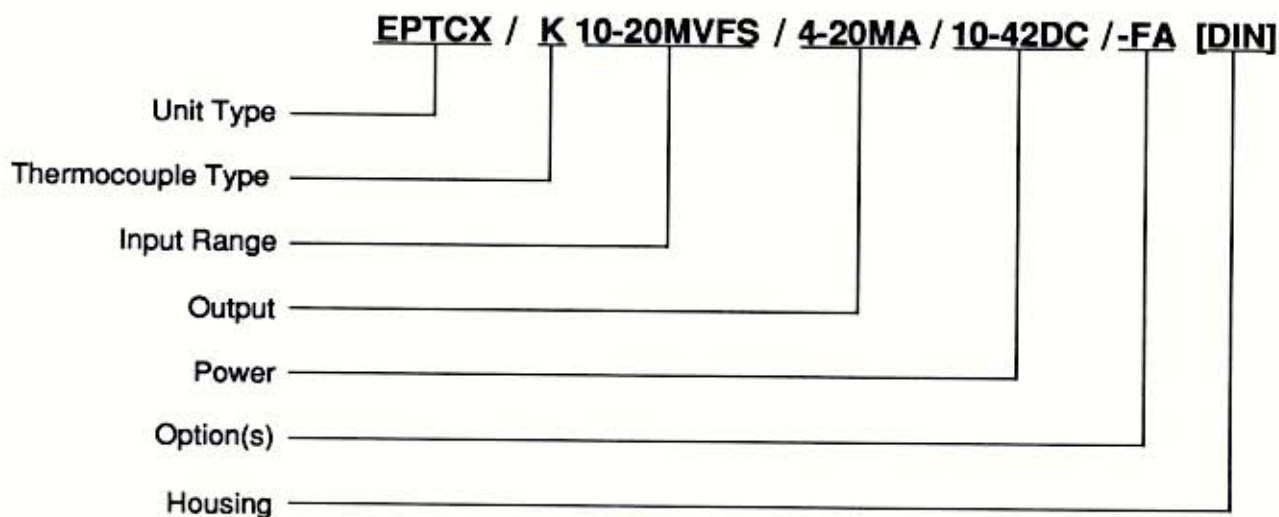

# EP-TCX

The external and internal zero potentiometers allow for adjustments of the unit's output to 0% for offsets of -75% to +90% of span (-40% to -75% of span requires negative EZ option). Offsets greater than +90% of span (+75 mV, maximum) requires the positive EZ option. The internal potentiometers are located on printed circuit board 2 (PC2).

Upon request, EP-TCX units are set and calibrated at the factory according to exact customer specification. If the parameters of your EP-TCX were set at the factory, small protective stickers are placed over the external potentiometer openings in the unit's front panel. If desired, these stickers may be removed to reconfigure/recalibrate the EP-TCX.

The coarse and fine adjustment potentiometers for zero, and the fine adjustment potentiometer for span require 15 turns to move their wipers from one end of the range to the other. Each is equipped with a slip-clutch, which prevents damage to the pot if it is turned too far during unit calibration. A slight change in torque will be felt when a wiper stop is reached (i.e., you may feel it start to "slip").

If the wiper stop is not detected, turn the potentiometer 15 turns in the desired direction to reach the wiper stop. The coarse span adjustment is a single-turn potentiometer.

## Calibration Equipment

Table 2 lists the user-supplied equipment needed to calibrate the EP-TCX.

If there are stickers over the zero and span potentiometers, the unit has been set, calibrated, and tested prior to shipment. The settings are according to customer specification, and there is no need to perform further calibration. Skip to the Installation Section of this manual.

If specific values for zero and span were not requested, the first step in calibrating the unit is to disassemble it in order to verify proper positioning of the internal printed circuit board (PCB) jumpers. It is the position of these jumpers that controls the operating parameters of the EP-TCX.

**Table 2. EP-TCX Calibration Equipment**

| Equipment   | Characteristics  |
|---|--|
| Compensated Thermocouple Calibrator                   | Ectron model 1120, Analogic model 6520, or equivalent; accurate to $\pm 0.05\%$  |
| DC Milliammeter<br>-or-<br>DC Voltmeter with Resistor | Fluke model 8800 or equivalent; accurate to $\pm 0.05\%$<br><br>Voltmeter: accurate to $\pm 0.05\%$<br>250 $\Omega$ ( $\pm 0.1\%$ ) resistor for calibration in 4-20 mA range<br>100 $\Omega$ ( $\pm 0.1\%$ ) resistor for calibration in 10-50 mA range |
| Power Supply  | 10 - 42 Vdc  |
| Thermocouple Wire (option)                            | Must be the same ISA type that will be used in the installation  |
| Screwdrivers  | Small Phillips-head, and slotted type with head no greater than 2.54 mm (0.1 inch) in width  |
| Pliers  | Needle-nosed, or technician's tweezers   |



# EP-TCX

The disassembly and the calibration procedure should be performed in a laboratory setting to allow the user to control input variables, and to monitor changes in the output more easily.

**EP-TCX Disassembly, HP Housing.** To access the jumpers on HP-housed units, first remove the four screws that secure the front panel to the housing (see figure 1), and remove the front panel. Take care not to damage the flex-circuit that connects the underside of the terminal block to the PCB chassis.

Next, remove the white plastic screw, mylar insulator, and nut from the side panel. This secures a power field-effect transistor (FET) to the housing.

Finally, loosen the black screw on the opposite side panel of the unit until the PCB chassis lifts free of the housing.

### **CAUTION**

*Do not damage the mylar insulators. These prevent grounding of both the of the PCB chassis and the FET to the unit housing. Both must be in place for proper operation of the EP-TCX.*

**EP-TCX Disassembly, DIN-style Housing.** To access the jumpers on DIN-style PCB's, first orient unit so that its front panel is facing forward, and the left side panel is on the bench. Remove the six Phillips-head screws that secure the right side panel to the housing (see figure 2).

Next, remove the white plastic screw, mylar insulator, and nut from the side panel. This secures a power field-effect transistor (FET) to the housing.

Finally, loosen the black screw just below the white screw, until PCB chassis lifts free of the housing. The top panel of the housing will fall free, and the terminal blocks may be removed with the PCB's.

### **CAUTION**

*Do not damage the mylar insulators. These prevent grounding of both the the PCB chassis and the FET to the unit housing. These must be in place for proper operation of the EP-TCX.*

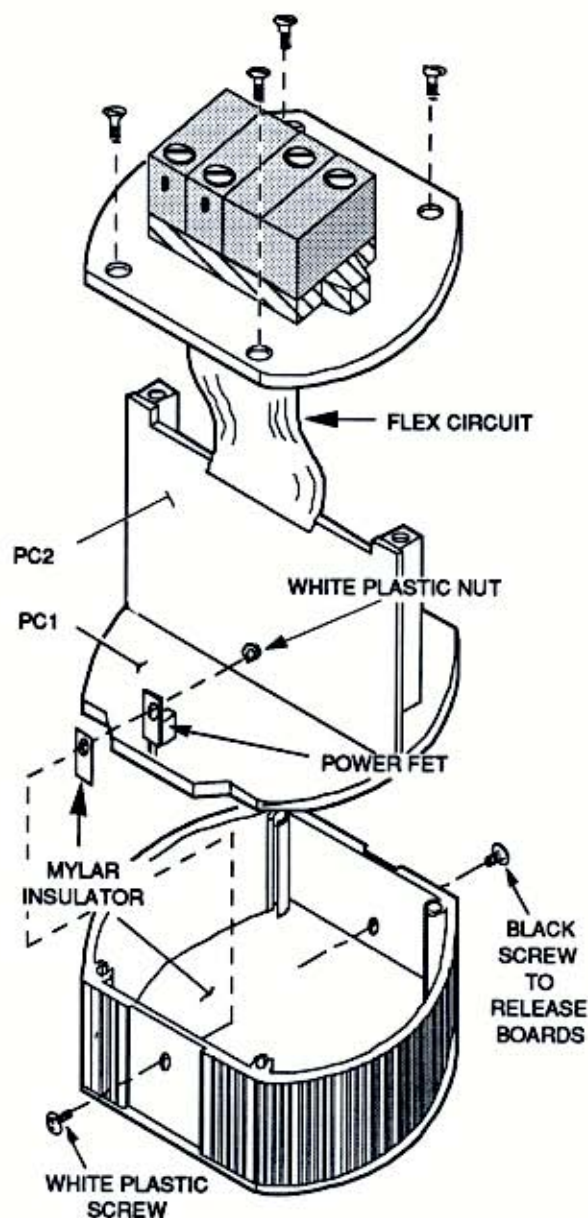

**Figure 1.** Disassembly of the HP-style EP-TCX

# EP-TCX

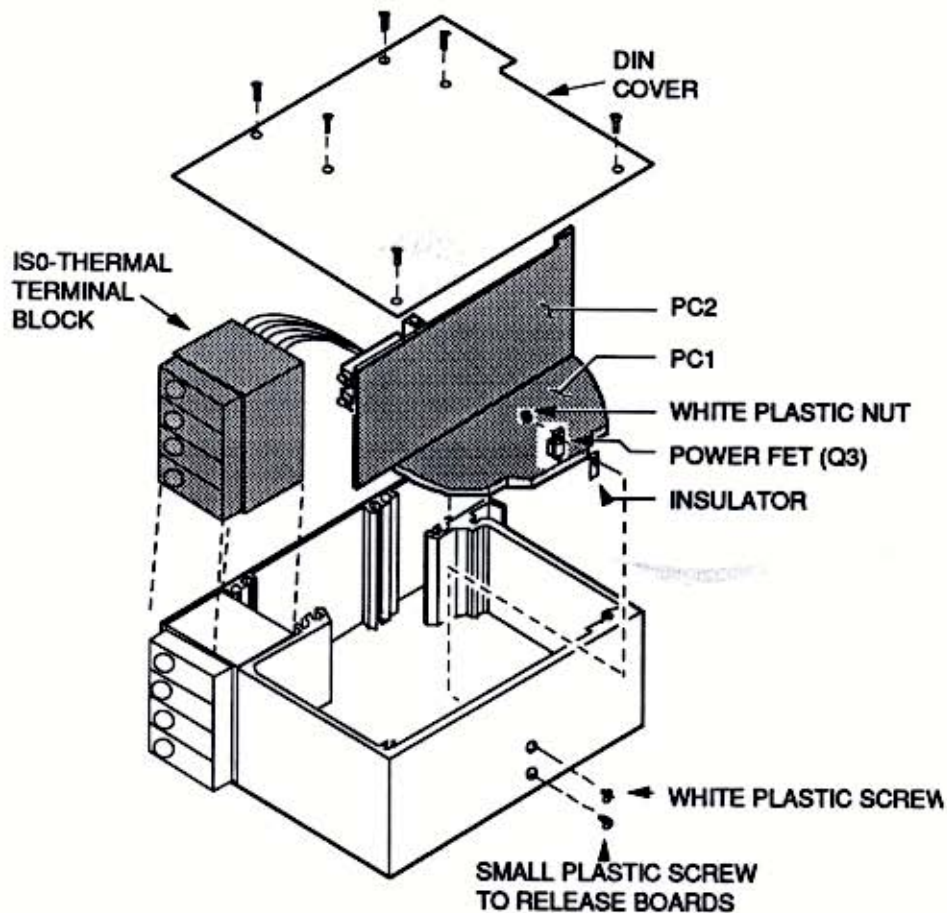

*Figure 2. Disassembly of the DIN-style EP-TCX*

## Verifying PCB Jumper Positions

For both types of units, the position of the jumpers on printed circuit board 1 (PC1) determine output range and indicate the presence of the EZ option. Jumper settings on PC2 set input range, thermocouple input type, and open thermocouple response.

**EP-TCX Units with the LSC Option.** If the jumpers installed on PC2 are all removed, or are in the storage position, it may be assumed that the unit was set to operate with the Low Input Span (LSC) Option. If your application calls for input of 2–5 mV, ensure that the unit model number shows LSC in the option field.



# EP-TCX

## CAUTION

Do not configure the EP-TCX for 2–5 mV input (LSC mode) unless the unit was ordered with the LSC Option. Removal of PCB jumpers J205 through J210 in a non-LSC-configured EP-TCX disables the common mode rejection capability of the unit. This may result in inaccurate output or equipment damage.

If you require the LSC Option but did not order it at the time of purchasing the EP-TCX, follow the instructions on the back cover of this manual, and return the unit to Moore Industries.

## Does Your Application Require the EZ Option?

Depending upon the application, some EP-TCX units may require a negative elevated zero for accurate output. Moore Industries' sales professionals will be happy to assist you in determining a requirement before shipping any EP-TCX units to you.

You may verify the requirement for a negative EZ yourself by determining the percentage of your application's "zero" that is represented by the anticipated span. That is, divide your zero by your span.

Convert the result to a percentage, and compare the value to the allowable percentages depicted on the graph in figure 3. If the "zero" from your application is –40% to –75% of the anticipated span, the EP-TCX will require the negative EZ option.

### For Example:

Suppose your application is to make use of a J-type thermocouple, and that the anticipated temperature range in the application will be between –150 and +100 °C (–238 to +212 °F). Published tables list the millivolt equivalents for that temperature range as –6.499 to +5.268 mV. This is a total span of 11.767 mV.

Zero from the application: –150 °C

Millivolt equivalent of zero: –6.499 mV

Total span from the application: 11.767 mV

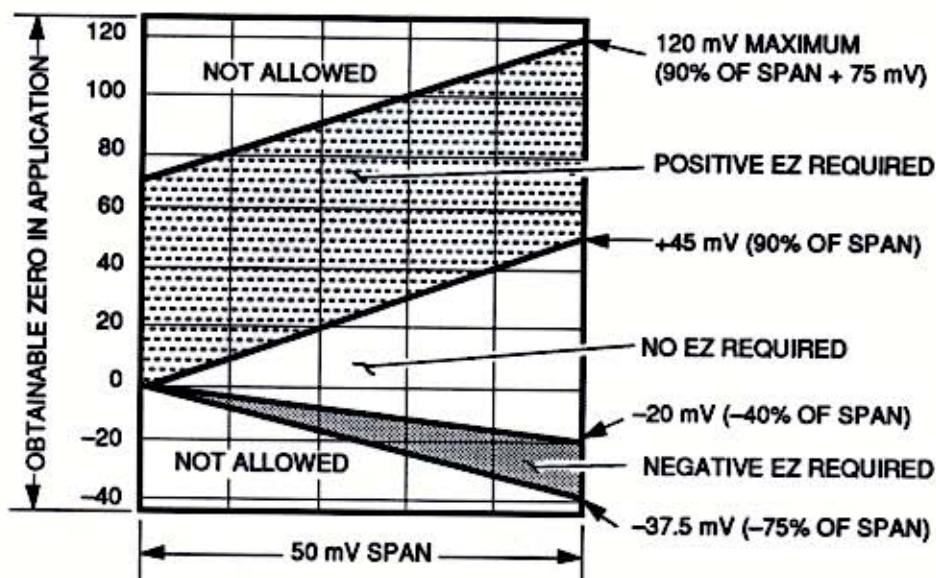

Figure 3. Determining the Requirement for the EZ Option

# EP-TCX

Dividing the anticipated "zero" of the application (-6.499) by the span (11.767) shows that the zero is -55.23% of the span:

$$-6.499 \div 11.767 = -0.55230, \\ \text{or approximately } -55\%$$

Since this is between -40% and -75%, the EP-TCX in this example will require the installation of the EZ option.

To verify the installation of the negative EZ option in your unit, disassemble the EP-TCX, and check to see that the jumper at J1 (on PC1) is in its "storage" position (set on one pin, or on J3 in figure 4).

Both normal operation, and Positive EZ (>90% of span to 75 mV maximum) require the installation of the jumper across both pins, as is shown for the J1 position in figure 4.

If your application requires a negative EZ, use needle-nose pliers to position the jumper in its storage position (across J3). Set the jumper across both pins of J1 for normal and Positive EZ operation.

Table 3 lists the jumper settings that are necessary to select the desired operating parameters for both the HP- and DIN-style EP-TCX's. HP-style jumpers and pots for both PC1 and PC2 are shown in figure 4. Figure 5 shows the location of jumpers on DIN-style EP-TCX PCB's.

**Table 3. EP-TCX Field-selectable PCB Jumper Positioning**

| Function   | Available Selections   | Jumper(s)   | Location                 |
|--|--|---|--------------------------|
| ISA Thermocouple Type                            | K or T<br>J<br>E<br>R or S   | J201 installed<br>J202 installed<br>J203 installed<br>J204 installed          | PC2<br>PC2<br>PC2<br>PC2 |
| Input  | 5 - 10 mV<br>10 - 20 mV<br>20 - 50 mV  | J207 and J209 installed<br>J205 and J210 installed<br>J206 and J208 installed | PC2<br>PC2<br>PC2        |
| Low Input Span Option (LSC)<br>(See Note, below) | Installed<br>NOT Installed   | J205 thru J210 NOT installed<br>J205 thru J210 installed                      | PC2<br>PC2               |
| Output   | 4 - 20 mA<br>10 - 50 mA  | J4 installed<br>J2 installed  | PC1<br>PC1               |
| Open Thermocouple Response                       | Upscale<br>Downscale   | J211 installed<br>J212 installed  | PC2<br>PC2               |
| Elevate Zero Option (EZ)                         | Negative EZ<br>(-40 to -75% of span)<br><br>Normal and Positive EZ<br>(-40 to greater than +90% of span) | J3 installed<br><br>J1 installed  | PC1<br><br>PC1           |

**NOTE:** Operation of the EP-TCX with the LSC Option requires the installation of additional electronic components. If the unit is to be configured to accept input between 2 and 5 mV, the "LSC" must appear in the unit model number. If it does not, contact the Customer Service Department.



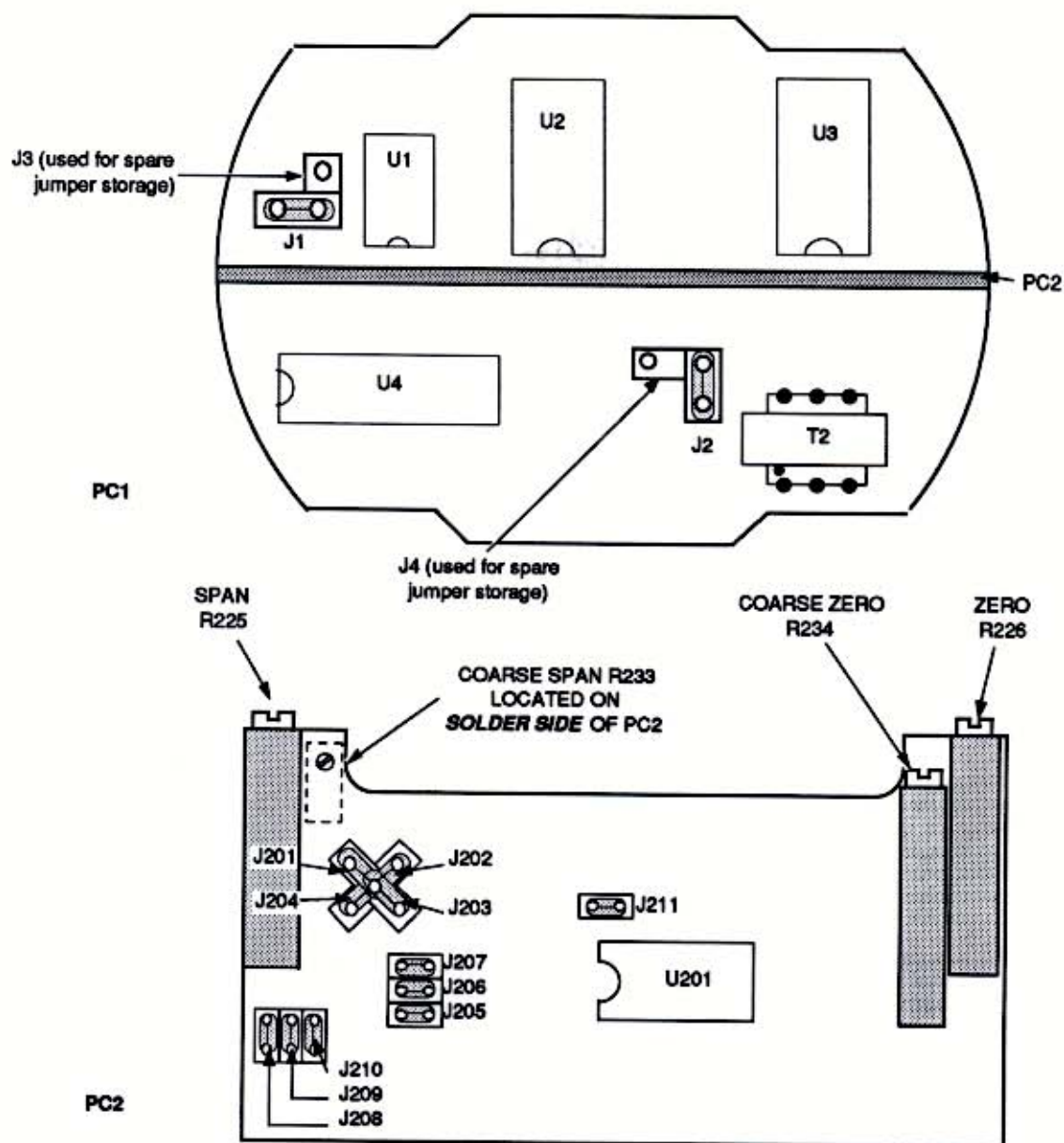

Figure 4. HP-style EP-TCX Jumpers and Potentiometers

# EP-TCX

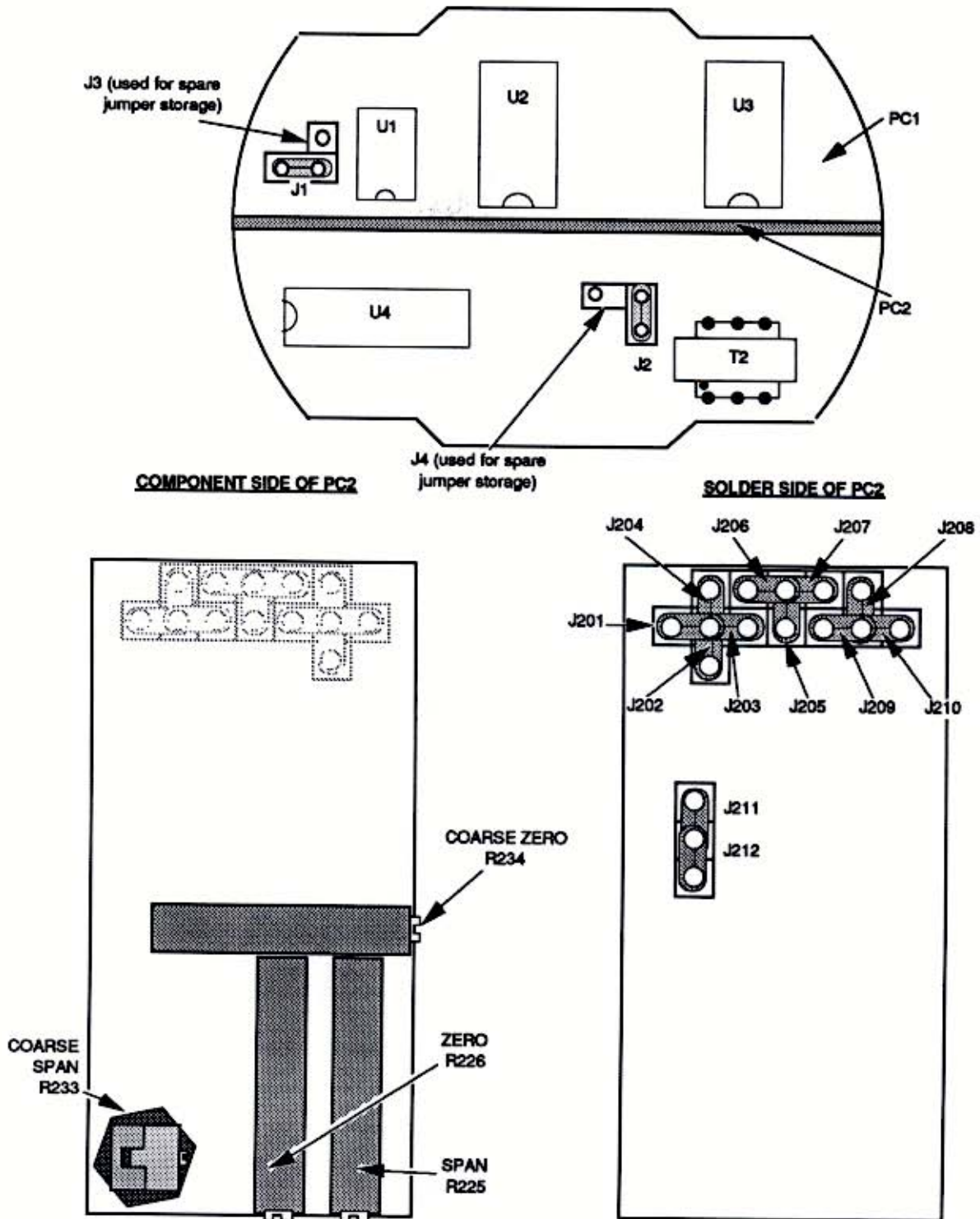

Figure 5. DIN-style EP-TCX Jumpers and Potentiometers



# EP-TCX

## Calibration Setup

The EP-TCX may be calibrated using either a dc milliammeter or a dc voltmeter/resistor combination figure 6 shows the calibration setup with both options.

**Using a DC Voltmeter/Resistor.** An output reading of 1 - 5 Vdc corresponds to the appropriate current output for the EP-TCX in the calibration setup. To obtain this voltage for units set for 4-20 mA output, use a load resistor of 250 ohms ( $\pm 0.02\%$ ). For 10 - 50 mA units, use a 100 ohm ( $\pm 0.02\%$ ) resistor.

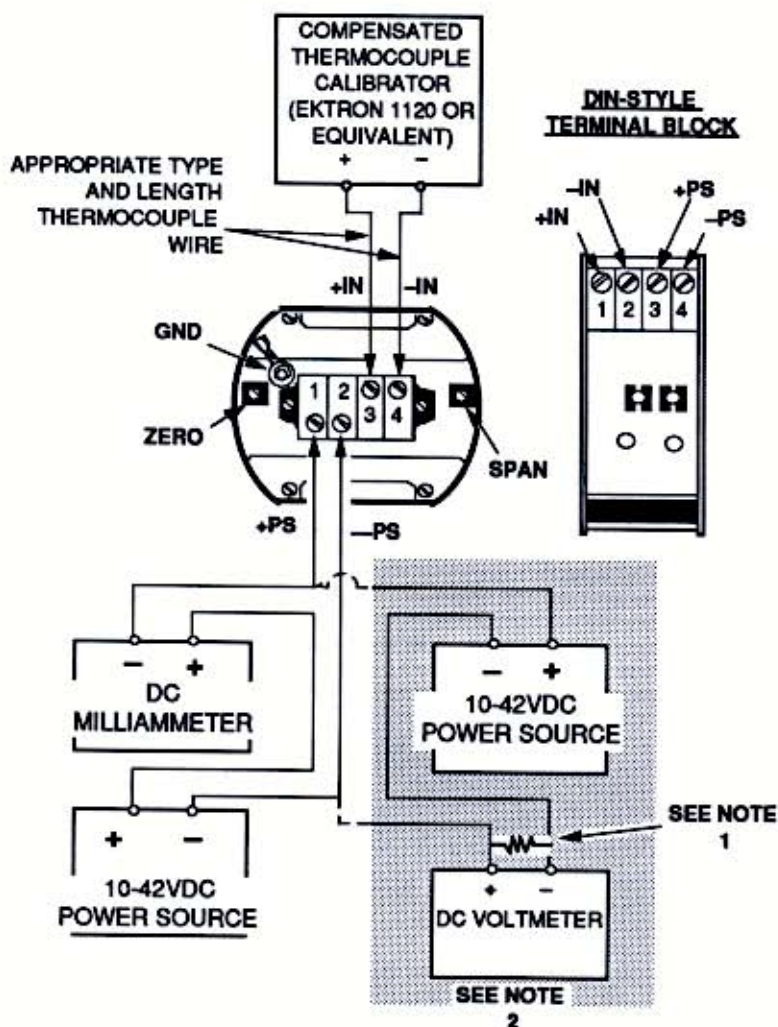

- NOTES:**
1. When using a voltmeter/resistor combination, the output reading should be 1-5 volts. A Load resistor of 250 ohms produces a 1-5 volt output equivalent to 4-20 mA. A resistor of 100 ohms produces a 1-5 volt output equivalent to 10-50 mA.
  2. Either milliammeter or voltmeter may be used for monitoring output.

Figure 6. EP-TCX Calibration Setup



# EP-TCX

## Before beginning the calibration procedure:

1. Connect the unit to be calibrated as shown in figure 6, set the zero and span fine adjustment potentiometers (R226 and R225 respectively) to midscale (approximately 7.5 turns from either wiper stop). See figures 4 or 5, as appropriate, for the location of the potentiometers.
2. Set the zero and span coarse adjustments (R234 and R233 respectively) fully counterclockwise. See figures 4 or 5, as appropriate, for the location of the potentiometers.
3. Apply 10-42 Vdc to setup and allow EP-TCX to warm up for 10 minutes.

## Calibration Procedure

To calibrate the EP-TCX:

1. Set input to rated 0% of mV (temperature range) input.
2. If using a milliammeter to monitor EP-TCX output, turn coarse zero potentiometer (see figure 4 or 5) clockwise until 0% of rated output is produced. For 4-20 mA-rated units, adjust for 4 mA output; for 10-50 mA-rated units, adjust for 10 mA.
3. If using a voltmeter/resistor combination, turn coarse zero potentiometer (see figure 4 or 5) clockwise until output is 1 volt,  $\pm 0.001$  V.
4. Set input to rated 100% of mV (temperature range) input.
5. If using a milliammeter, turn coarse span potentiometer (see figure 4 or 5) clockwise until output is 20 mA for LSC, 5-10, and 10 mV units. For 20-50 mV units, adjust until output is 50 mA.
6. If using a voltmeter/resistor combination, turn coarse span (see figure 4 or 5) clockwise until output is 5 volts,  $\pm 0.001$  V.

7. Repeat steps 1 through 6 until the output readings do not fluctuate when switching from minimum to maximum rated input.
8. Turn the fine adjustment potentiometers for zero and span (R226 and R225 respectively) clockwise until the EP-TCX is set to preference or requirement.
9. Determine values for 25%, 50%, and 75% of the millivolt span of the unit, and set the calibrator to these values.

### For Example:

An EP-TCX is being calibrated for a span of  $-150$  °C to  $+100$  °C, or from published tables,  $-6.499$  mV to  $+5.268$  mV. This is a span of  $+11.767$ , or roughly 12 mV.

Settings for the calibrator in this case then, should be  $-3.557$  mV for 25%,  $-0.616$  mV for 50%, and  $+2.258$  mV for 75%.

10. Note the output at each setting and verify that the output is linear throughout the operating range of the unit being calibrated.

The unit is now calibrated, and may be re-assembled and placed into service.

**EP-TCX Re-assembly.** This procedure is essentially the inverse of the steps to disassemble the unit.

### CAUTION

*All mylar insulators must be re-installed for the EP-TCX to function properly.*

First, replace the mylar insulator and PCB chassis in the housing, and secure it there by tightening the small retaining screw (refer to step 3 of the Disassembly procedure). Then secure the power FET to the housing using the white plastic screw, insulator, and nut.

Finally, re-seat the panel on the unit housing, and secure it using the appropriate screws.



# EP-TCX

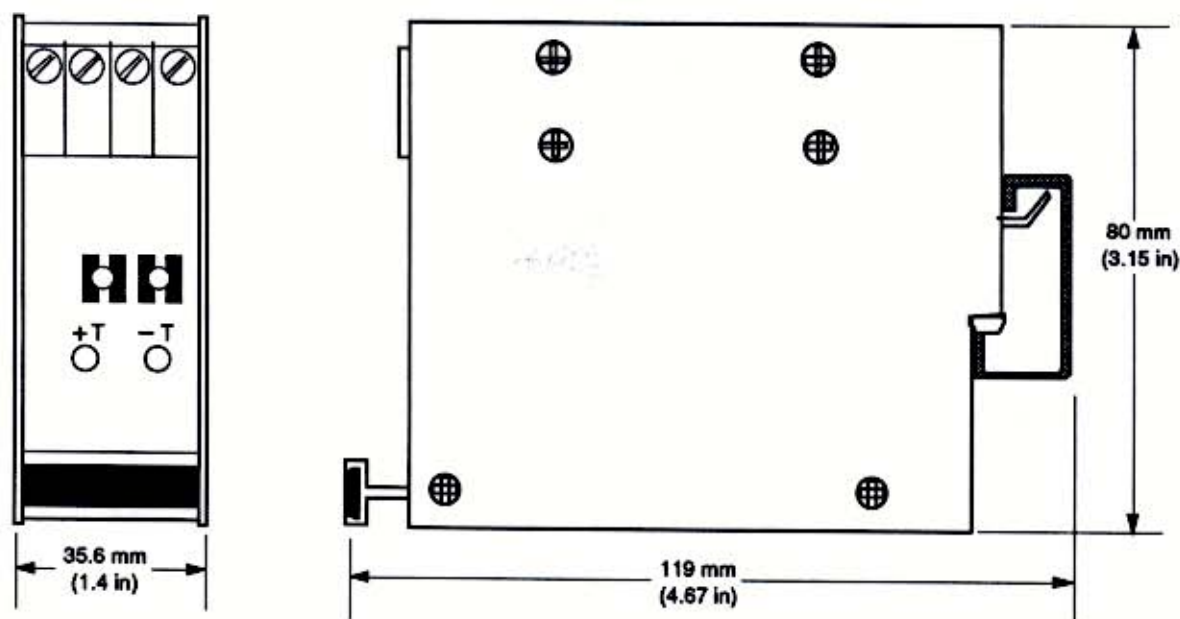

Figure 8. DIN-style EP-TCX Outline Dimensions

For information on available protective enclosures, contact your local Sales Representative or the Customer Service Department of Moore Industries at 1-800-999-2900.

## Electrical Connections

Figure 9 shows the EP-TCX in a typical application. A Moore Industries 240 mA DPS may be used to supply 24 Vdc to the EP-TCX. Complete temperature transmitter assemblies, including sensors, thermo-wells, and fittings are also available.

The four terminal blocks on the front panel of every EP-TCX are labeled "+IN", "-IN", "+PS", and "-PS". The "IN" terminals are for connecting the input from the thermocouple, and the "PS" terminals are output. Figure 9 depicts the terminal blocks for both the HP- and DIN-style EP-TCX.

To complete the connections, loosen the clamping screws on the appropriate terminal blocks, insert the uninsulated end of the connecting wire, and re-tighten the screw while holding the wire in place.

Finally, tag the wire for later identification.

For connecting the unit to power supply, 14-22 AWG insulated copper wire is recommended.

To avoid transients and stray pick-ups, use twisted conductors when running close to other services.

### **NOTE**

*The use of shielded, twisted pair wiring is recommended for all low-level signals.*

In connecting the thermocouple to the unit, remember to use the type of wire that was used to calibrate the EP-TCX. Using different, or non-ISA standard wire will result in erroneous data.

# EP-TCX

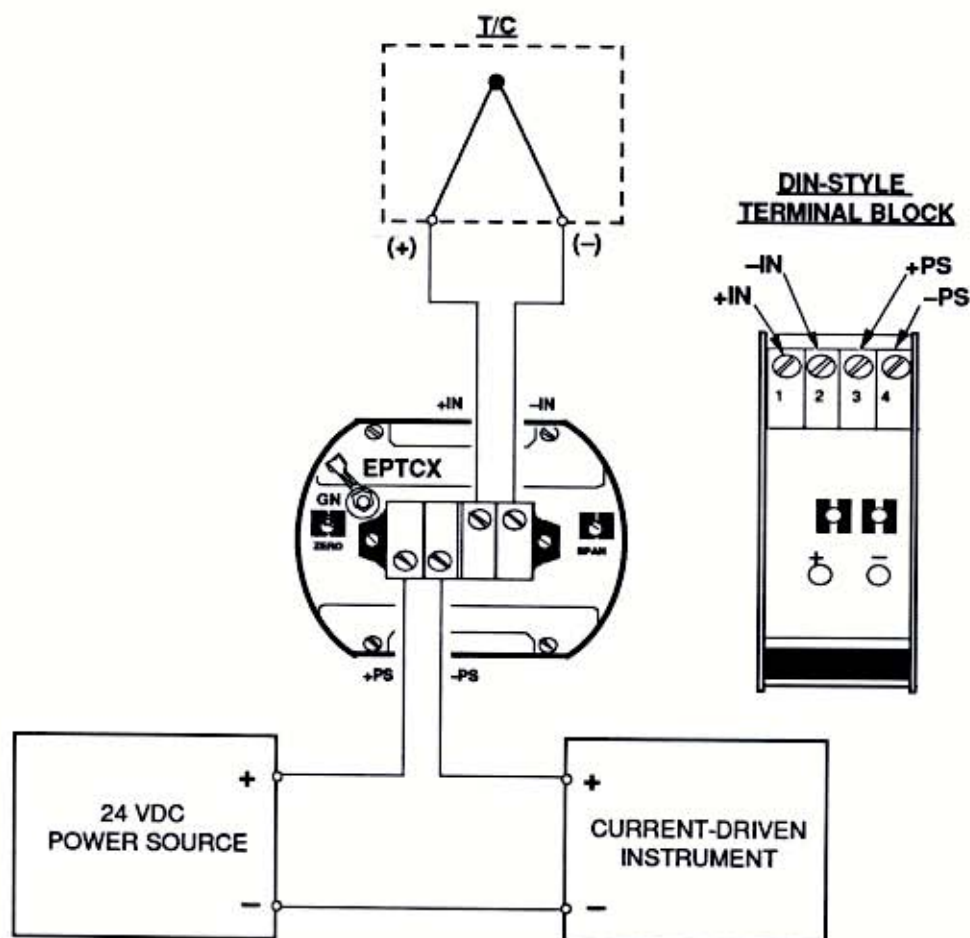

Figure 9. Typical EP-TCX Installation Hookup

## Maintenance

The EP-TCX operates from a source of 10 to 42 Vdc (loop power). Once calibrated, installed, and supplied with power, the unit will operate unattended, and maintenance-free.

During normal operation, the unit may become warm, especially in areas where the ambient temperature is high. This condition does not impair the EP-TCX's operation, and may be disregarded as long as the ambient temperature stays within the  $-29$  to  $+82$  °C ( $-20$  to  $+180$  °F) rated ambient temperature operating range, as appears in table 1. If performance is impaired, call Moore Industries' Customer Service Department.



# EP-TCX

---

Maintenance of the EP-TCX is limited to a periodic check of the connection terminals of the installed unit. Keep the terminals clean and tight, and ensure that there is adequate ventilation or heat dissipation for the unit.

## Troubleshooting

If a problem develops with the performance of the EP-TCX, remove and recalibrate the unit. Refer to the Calibration Section of this manual.

DIN-style EP-TCX units have test jacks on the front panel labeled +T and -T, which may be used to verify current output without removing the unit from service. The probes used should be 2.03 mm (0.08 in) in diameter, and 12.7 mm (0.50 in) long, maximum.

Any units found to be performing below specification after re-calibration should be returned to Moore Industries immediately. Instructions for the return of the equipment are on the back cover of this manual. Customers may also contact Moore Industries' Customer Service Department for assistance.

# RETURN PROCEDURES

## To return equipment to Moore Industries for repair, follow these four steps:

1. Call Moore Industries and request a Returned Material Authorization (RMA) number.

### Warranty Repair –

If you are unsure if your unit is still under warranty, we can use the unit's serial number to verify the warranty status for you over the phone. Be sure to include the RMA number on all documentation.

### Non-Warranty Repair –

If your unit is out of warranty, be prepared to give us a Purchase Order number when you call. In most cases, we will be able to quote you the repair costs at that time. The repair price you are quoted will be a "Not To Exceed" price, which means that the actual repair costs may be less than the quote. Be sure to include the RMA number on all documentation.

2. Provide us with the following documentation:
  - a) A note listing the symptoms that indicate the unit needs repair
  - b) Complete shipping information for return of the equipment after repair
  - c) The name and phone number of the person to contact if questions arise at the factory
3. Use sufficient packing material and carefully pack the equipment in a sturdy shipping container.
4. Ship the equipment to the Moore Industries location nearest you.

The returned equipment will be inspected and tested at the factory. A Moore Industries representative will contact the person designated on your documentation if more information is needed. The repaired equipment, or its replacement, will be returned to you in accordance with the shipping instructions furnished in your documentation.

### WARRANTY DISCLAIMER

THE COMPANY MAKES NO EXPRESS, IMPLIED OR STATUTORY WARRANTIES (INCLUDING ANY WARRANTY OF MERCHANTABILITY OR OF FITNESS FOR A PARTICULAR PURPOSE) WITH RESPECT TO ANY GOODS OR SERVICES SOLD BY THE COMPANY. THE COMPANY DISCLAIMS ALL WARRANTIES ARISING FROM ANY COURSE OF DEALING OR TRADE USAGE, AND ANY BUYER OF GOODS OR SERVICES FROM THE COMPANY ACKNOWLEDGES THAT THERE ARE NO WARRANTIES IMPLIED BY CUSTOM OR USAGE IN THE TRADE OF THE BUYER AND OF THE COMPANY, AND THAT ANY PRIOR DEALINGS OF THE BUYER WITH THE COMPANY DO NOT IMPLY THAT THE COMPANY WARRANTS THE GOODS OR SERVICES IN ANY WAY.

ANY BUYER OF GOODS OR SERVICES FROM THE COMPANY AGREES WITH THE COMPANY THAT THE SOLE AND EXCLUSIVE REMEDIES FOR BREACH OF ANY WARRANTY CONCERNING THE GOODS OR SERVICES SHALL BE FOR THE COMPANY, AT ITS OPTION, TO REPAIR OR REPLACE THE GOODS OR SERVICES OR REFUND THE PURCHASE PRICE. THE COMPANY SHALL IN NO EVENT BE LIABLE FOR ANY CONSEQUENTIAL OR INCIDENTAL DAMAGES EVEN IF THE COMPANY FAILS IN ANY ATTEMPT TO REMEDY DEFECTS IN THE GOODS OR SERVICES, BUT IN SUCH CASE THE BUYER SHALL BE ENTITLED TO NO MORE THAN A REFUND OF ALL MONIES PAID TO THE COMPANY BY THE BUYER FOR PURCHASE OF THE GOODS OR SERVICES.

ANY CAUSE OF ACTION FOR BREACH OF ANY WARRANTY BY THE COMPANY SHALL BE BARRED UNLESS THE COMPANY RECEIVES FROM THE BUYER A WRITTEN NOTICE OF THE ALLEGED DEFECT OR BREACH WITHIN TEN DAYS FROM THE EARLIEST DATE ON WHICH THE BUYER COULD REASONABLY HAVE DISCOVERED THE ALLEGED DEFECT OR BREACH, AND NO ACTION FOR THE BREACH OF ANY WARRANTY SHALL BE COMMENCED BY THE BUYER ANY LATER THAN TWELVE MONTHS FROM THE EARLIEST DATE ON WHICH THE BUYER COULD REASONABLY HAVE DISCOVERED THE ALLEGED DEFECT OR BREACH.

### RETURN POLICY

For a period of thirty-six (36) months from the date of shipment, and under normal conditions of use and service, Moore Industries ("The Company") will at its option replace, repair or refund the purchase price for any of its manufactured products found, upon return to the Company (transportation charges prepaid and otherwise in accordance with the return procedures established by The Company), to be defective in material or workmanship. This policy extends to the original Buyer only and not to Buyer's customers or the users of Buyer's products, unless Buyer is an engineering contractor in which case the policy shall extend to Buyer's immediate customer only. This policy shall not apply if the product has been subject to alteration, misuse, accident, neglect or improper application, installation, or operation. THE COMPANY SHALL IN NO EVENT BE LIABLE FOR ANY INCIDENTAL OR CONSEQUENTIAL DAMAGES.



**WORLDWIDE • www.miinet.com**

|  |  |  |
|--|--|--|
| United States • info@miinet.com<br>Tel: (818) 894-7111 • FAX: (818) 891-2816   | Belgium • info@mooreind.be<br>Tel: 03/448.10.18 • FAX: 03/440.17.97            | China • sales@mooreind.sh.cn<br>Tel: 86-21-62491499 • FAX: 86-21-62490635    |
| Australia • sales@mooreind.com.au<br>Tel: (02) 8536-7200 • FAX: (02) 9525-7296 | The Netherlands • sales@mooreind.nl<br>Tel: (0)344-617971 • FAX: (0)344-615920 | United Kingdom • sales@mooreind.com<br>Tel: 01293 514488 • FAX: 01293 536852 |